



Thanks for purchasing our product, please read this manual carefully before using it

Please be sure to keep it for future reference

This manual is subject to change without any notice

Orbita shall not be held accountable for any accident and hazard arising from
incorrect user operations



Orbita Smart Bluetooth Door Lock

P7023N

Huizhou Orbita Technology Co., Ltd. (Marketing Center and Manufacturing Base in China)
Address: Orbita Technology Park, Changbu Village, Xinxu Town, Huiyang District, Huizhou,
Guangdong Province, P.R.C

Tel: +86-752-3633501 +86-752-3633502 +86-752-3633503

Fax: +86-752-3633600; +86-752-3633900

Customer Service Hotline: 400-834-6688

(Huizhou Orbita Technology Co., Ltd. reserves the right of final interpretation of this manual)

Installation and User Manual

V2020-01

Table of Contents:

1 : Product Overview

1-1:Appearance	2
1-2:Features	2
1-3:Technical Specifications	3
1-4:Safety Precautions	4
1-5:Charging Safety	4
1-6:Precautions for Use	4

2 : Product Installation

2-1:Product List	5
2-2:Installation Instructions	5
2-3:Installation Precautions	6
2-4:Installation Steps	6
2-5: Installation Diagrams	8

3 : Operating Guide (operate with the app)

APP download	8
1:Add lock on the APP	9
2: eKey	10
3: User password	11
4: IC card	12
5:Automatic locking	12
6:Low power warning	13
7:Keypad lock out	13
8: Delete Bluetooth Administrator	13

WEB Management login

1. Product Overview

1-1 : Appearance

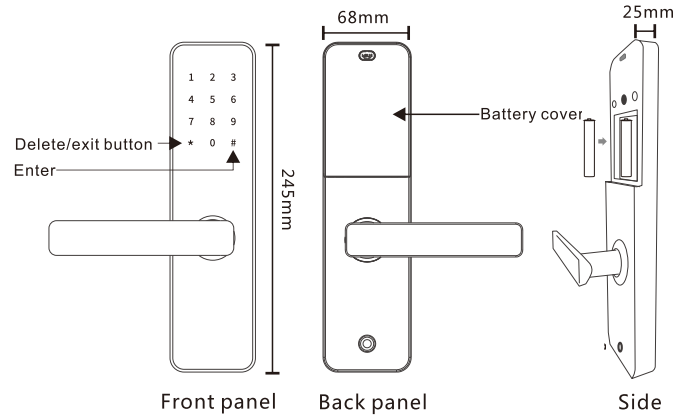

1-2 : Features

1. Material: high-end aluminum alloy
2. Support password unlock
3. Support card unlock
4. Support phone bluetooth app unlock
5. Support touch lock unlock
6. Support password remotely (permanent, Timed, one-time, Erase, Custom, cyclic)
7. Unlocking record query

1-3 : Technical Specifications

Panel material	High-end aluminum alloy
Latch material	SUS304
Door thickness	40-110mm
Cylinder	Concealed super grade B mechanical cylinder
Operating temperature	-20°C- +60°C
Bluetooth standard	4.1BLE
Support phone system	Android 4.3/IOS7.0 above
Working voltage	4 AA Alkaline batteries
Low battery voltage alarm	4.8V
Static current	60uA
Operating current	< 200mA
Unlock time	≈1.5"
Button type	Capacitive touch button
Password capacity	150pieces
Card type	MIFARE M1 card
Card capacity	200 pieces
Unlocking method	APP, Password, Card, Mechanical key, Bluetooth

1-4: Safety Precautions

1. Keep the panel away from corrosive substances to avoid damage to the surface coating.
2. Do not operate the product with wet hands to prevent liquids such as water or drinks from entering the lock body.
3. Do not press the keypad with excessive force or with sharp objects.
4. Keep your fingers clean while using this product. To ensure normal use, keep the fingerprint area clean as the surface may become smudged after it is used for a period of time.
5. Do not pull the product with excessive force.
6. Do not use water, benzene or alcohol to clean the product; use a soft and dry cloth to clean the lock body.

1-5: Charging Safety

1. This product uses 4 AA alkaline dry batteries, please install the battery according to the correct positive and negative electrodes.
2. When the voltage is lower than 4.8V, a low voltage alarm will sound every time the lock is unlocked. Pay attention to replace the battery in time.
3. Do not short the positive and negative terminals of the battery.
4. Please use the specified battery in this product, do not connect other batteries modified by yourself.
5. Do not discard the replaced battery to avoid polluting the environment.

1-6: Precautions for Use

1. Do not install batteries before the lock is installed on the door.
2. Please carefully keep your password and change it on a regular base to prevent leaks.
3. Charge or replace the batteries within one week after the battery replacement alarm sounds.
4. Make sure that the door is completely locked when leaving.
If you fail to open the door using the fingerprint, password or card, you can use the mechanical key. Please keep the mechanical key properly.

2. Product Installation

2-1: Product List

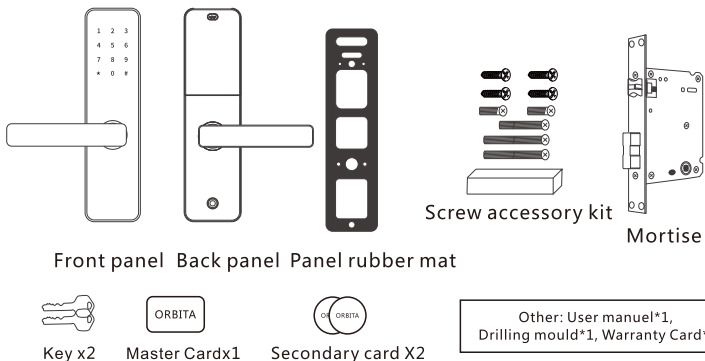

Note : The door lock frame is larger than 40mm, and the door thickness can be installed within the range of 40-50mm. If the door thickness is greater than 50mm, a rectangular bar is required, and ask seller for it. Please check if the list is complete after unpacking. If there is any missing, please ask the seller in time.

2-2: Installation Instructions

Confirm the door handing (this smart lock can be used for left-hand outswing, left-hand inswing, right-hand inswing and right-hand outswing doors)

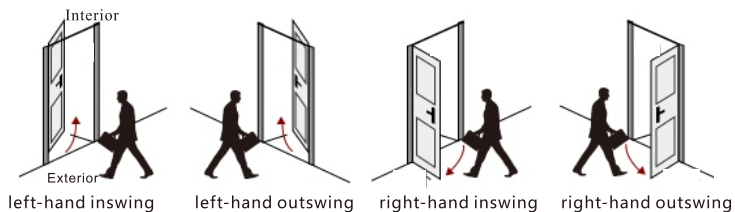

2.3 Installation Precautions

Please check the accessories before installing the door lock. After completing the installation, you can continue to install. If your door hole needs to be punched, please seek the help of a professional lock installer. Unauthorized handling may result in unnecessary property damage.

2.4 Installation Steps

- 1 Mortise installation as shown
- 2 Adjust direction as shown
- 3 Install square rod and screw sleeve as shown

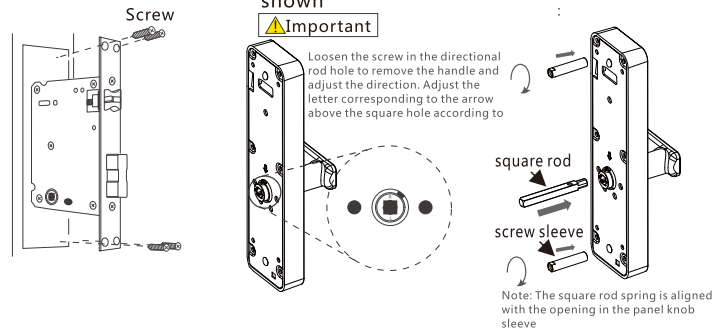

- 4 Install the front panel into the panel with the hole open
- 5 Fixed front and rear panels

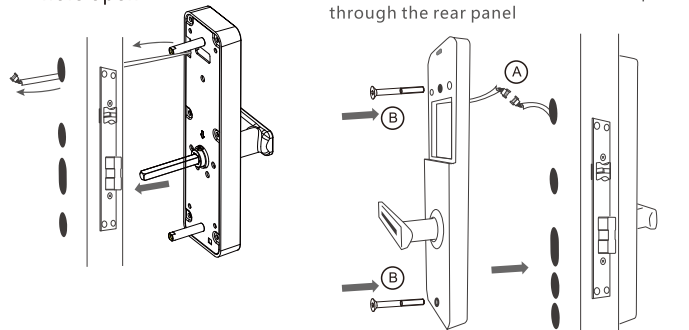

6 Install battery

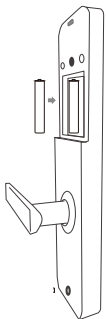

7 Install the battery cover

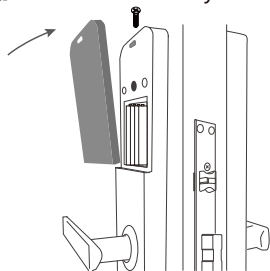

8 Lift the handle and the lock latch out as normal

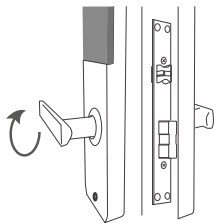

9 Touch the panel with your finger, the 5 and # keys flash as normal, enter the "123456" initial password to open the door.

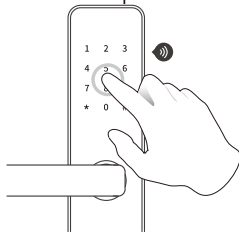

10 Add administrator in the APP



11 Standard Mortise

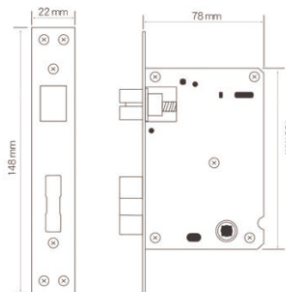

2-4: Installation Diagrams

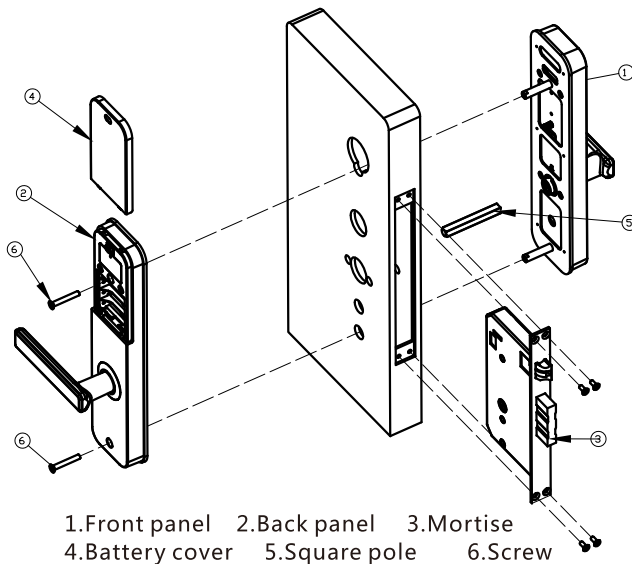

1.Front panel 2.Back panel 3.Mortise
4.Battery cover 5.Square pole 6.Screw

3.Operating Guide

Operate with the app

software download

Download " orbita smart " from app store/google play etc.

1 Add lock on the APP

1-1:Bluetooth matching with APP

After power-on, with the front panel keyboard backlight off :

- ①Click any number on the touch screen to activate the door lock;
- ②Open the app software;
- ③Click " Add Lock " and select the door lock type
- ④Click on the name of the lock device, and the addition is successful.

If not, repeat the above steps, or press and hold the panel to reset, hear the voice prompt and try again.

1-2:Reset

If you have an abnormal situation during the APP binding or using process, you can press and hold this button for a long time to hear the "Didi"

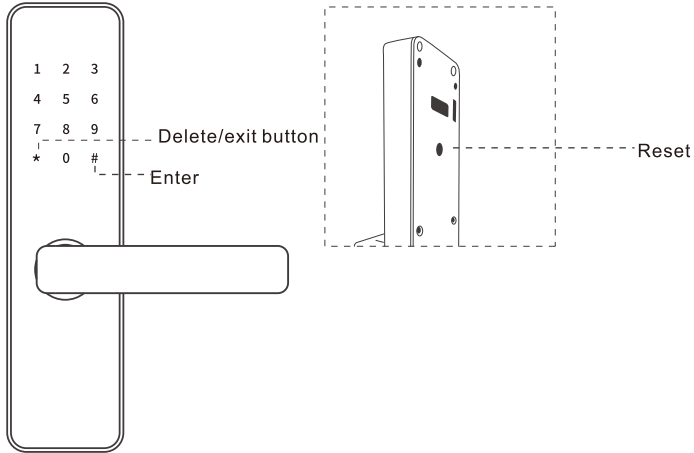

2 :ekey

2.1 send an ekey

Notice: You DO Not need to be near the lock to send an ekey. You can send an ekey ANYWHERE, ANYTIMETHE recipient of the ekey must have anAppaccount.

2.1.1 Activate the APP

2.1.2 select the lock

2.1.3 press [send ekey]

2.1.4 set the parameters of the ekey and press [send] to share it with other registered users.

2.2 unlock with ekey

Notice: please turn on the Bluetooth of your phone and keep it close to the lock

2.2.1 "touch to open"

2.2.1.1 Activate the APP

2.2.1.2 Activate the lock by pressing "*" or touching the keypad to light it UP

2.2.1.3 The lock said "dingdong", the message show the lock have been unlocked.

2.2.2 unlock with APP

2.2.2.1 Activate the APP

2.2.2.2 select the lock

2.2.2.3 press the lock icon on the APP

2.2.2.4 The lock said "dingdong", the message show the lock have been unlocked.

2.3 Delete an ekey

Notice: You Do not need to be near the lock to delete an ekey. You can delete an ekey ANYWHERE, ANY Time but the deletion will only become effective when the ekey user' s App is activated and connected to the internet. If the deletion is carried out near the lock with Bluetooth on, the deletion become effective immediately.

2.3.1 Activate the APP

2.3.2 select the lock

2.3.3 press [Password management]

2.3.4 select the ekey to be deleted

2.3.5 press [delete]

3 user password

3. 1 Generate a user password

Notice: You Do not need to be near the lock to generate a user passcode.

You can generate a user passcode ANYWHERE, ANYTIME.

3. 1. 1 Activate the APP

3. 1. 2 select the lock

3. 1. 3 press [generate passcode]

3. 1. 4 set the parameters of the passcode as prompted and press

[generate]

3. 1. 5 when the passcode appears on the screen, press the sharing icon on

the upper right corner of the screen to share it with other users

3. 2 unlock with password

3. 2. 1 Activate the lock by pressing "*" or touching the keypad to light it up

3. 2. 2 input passcode and press "#(pressing "*" will delete the digit last entered during the input)

3. 2. 2. 1 if the passcode is correct, Lock with long "beep"

3. 2. 2. 2 if the passcode is incorrect, Lock with 4 times "beep"

3. 2. 2. 3 if the lock detects 5 consecutive trials of incorrect passcode

consists of more than 4 digits, Lock with 4 times "beep", after two times,

the system will be locked for 5 minutes.

3. 2. 2. 4 if the passcode has expired, voice prompt unauthorized passcode

3. 3 Modify user password on the lock

3. 3. 1input[*10#]

3. 3. 2 input original passcode

3. 3. 3 The lock with 2 times short "beep" if the password is correct.

3. 3. 3. 1 input a new passcode

3. 3. 3. 2 Enter new password again with 2 times "beep".

3. 3. 3. 3 input [new passcode#]

3. 3. 3. 4 Lock with 2 times long "beep" (the lock with 4 "beep" if the

password is wrong when you enter in second time)

3.3.4 if the original passcode is correct

3.3.4.1Lock with 4 times "beep"

3.4 Delete a passcode

Notice: please turn on the Bluetooth of your phone and keep it close to the

lock

3. 4. 1 Activate the APP

3. 4. 2 select the lock

3. 4. 3 press [passcodes] 3. 4. 4 select the pass code to be deleted

3. 4. 5 press [delete]

4 card(available on selected models)

4. 1 Add an IC card

Notice: please turn on the Bluetooth of your phone and keep it close to the lock

4. 1. 1 Activate the APP

4. 1. 2 select the lock

4. 1. 3 press [IC cards] 4. 1. 4 press the "⌘" sign on the upper right corner of the screen

4. 1. 5 press [add IC card]

4. 1. 6 Then click "enter"

4. 1. 7 The screen lights up, 2 times short "beep"

4.1. 8 Long "beep" means swipe card success.

4. 2 unlock with IC card

4. 2. 1 place a card near the reader area on the keypad of the lock

4. 2. 1. 1 Lock with short "beep" and show "unlocked"

4. 2. 1. 2 Lock with 4 times "beep" in two times, it means the card invalid.

4. 2. 1. 3 Lock with 4 times "beep" in one time, it means operation failed.

4. 3 Delete an IC card

Notice: please turn on the Bluetooth of your phone and keep it close to the lock

4. 3. 1 Activate the APP

4. 3. 2 select the lock

4. 3. 3 press [IC cards]

4. 3. 4 select the IC card to be deleted

4. 3. 5 press [delete]

5 Auto lock

5. 1 5 seconds after the lock is unlocked, it automatically locks and gives a voice prompt "(locked)"(except it is set to passage mode).

5. 2 The length of time before auto lock can be customized in the [settings] menu of the lock.

6 low power warning

6. 1 when the battery is low, the keypad will light up and flash for a second after it is activated, meanwhile the lock gives a voice prompt "battery is low, please replace" .

7 keypad lockout

7. 1 When the user enters the incorrect password for 5 times (the password length is greater than or equal to 4), the door lock will beep twice, and the password keyboard will be locked for 5 minutes.

7. 2 During the lockout period, the keypad light will flash quickly on each pressing. Unlocking with APP card or fingerprint is still functional in this case, and the keypad will be back to normal once it is unlocked successfully with an APP or a card

7. 3 The keypad will be re-enabled after 5 minutes lockout and user can continue to input passcode. However, each wrong passcode trial will result in 5 minutes lockout thereafter.

8 Delete Bluetooth Administrator/restore to default factory

setting Warning: once the Bluetooth Administrator is deleted, the lock is set to default factory setting , all previous passcodes cards and fingerprints are invalidated.

8.1 Delete Bluetooth Administrator on the APP

Notice: please turn on the Bluetooth of your phone and keep it close to the lock.

8. 1. 1 Activate the APP

8. 1. 2 select the lock

8. 1. 3 press [settings]

8. 1. 4 press [delete]

8. 1. 5 input the account password and press [OK]

8. 1. 6 The lock with 2 times "beep" means delete success.

8. 2 Delete Bluetooth Administrator on the lock

8. 2. 1 long press the reset button

8. 2. 2 Lock with 2 times "beep"

8. 2. 3 It means "Administrator deleted successfully"

WEB management login

Open browser and input: lock.orbitasmart.com, then input user name and password (the ID is same as APP).